



Department of  
Primary Industries and  
Regional Development

Digital Library

---

Fisheries occasional publications

Fishing & aquaculture

---

11-2015

## Technical Manual for Camera Surveys of Boat and Shore-Based Recreational Fishing in Western Australia

Stuart J. Blight

*Department of Fisheries, Western Australia*, [stuart.blight@dpird.wa.gov.au](mailto:stuart.blight@dpird.wa.gov.au)

C.B. Smallwood

*Department of Fisheries, Western Australia*, [claire.smallwood@dpird.wa.gov.au](mailto:claire.smallwood@dpird.wa.gov.au)

Follow this and additional works at: [https://library.dpird.wa.gov.au/fr\\_fop](https://library.dpird.wa.gov.au/fr_fop)



Part of the [Aquaculture and Fisheries Commons](#)

---

### Recommended Citation

Blight, S J, and Smallwood, C. (2015), *Technical Manual for Camera Surveys of Boat and Shore-Based Recreational Fishing in Western Australia*. Department of Fisheries, Perth, Western Australia. Book Fisheries Occasional Publication No. 121.

[https://library.dpird.wa.gov.au/fr\\_fop/23](https://library.dpird.wa.gov.au/fr_fop/23)

This book is brought to you for free and open access by the Fishing & aquaculture at Digital Library. It has been accepted for inclusion in Fisheries occasional publications by an authorized administrator of Digital Library. For more information, please contact [library@dpird.wa.gov.au](mailto:library@dpird.wa.gov.au).

**Technical Manual for Camera  
Surveys of Boat- and Shore-Based  
Recreational Fishing in  
Western Australia**

Stuart Blight and Claire Smallwood



Government of **Western Australia**  
Department of **Fisheries**

Department of Fisheries  
3rd floor, The Atrium  
168 – 170 St Georges Terrace  
PERTH WA 6000  
Telephone: (08) 9482 7333  
Facsimile: (08) 9482 7389  
Website: [www.fish.wa.gov.au](http://www.fish.wa.gov.au)  
ABN: 55 689 794 771

© Department of Fisheries, Western Australia. November 2015.  
ISSN: 1447 - 2058 ISBN: 978-1-921845-91-8

## TABLE OF CONTENTS

<b>1.0</b>	<b>EXECUTIVE SUMMARY .....</b>	<b>1</b>
<b>2.0</b>	<b>INTRODUCTION .....</b>	<b>1</b>
<b>3.0</b>	<b>SURVEY OBJECTIVES AND SCOPE .....</b>	<b>2</b>
<b>3.1</b>	<b>Survey Objectives.....</b>	<b>2</b>
<b>3.2</b>	<b>Survey Duration .....</b>	<b>2</b>
<b>3.3</b>	<b>Survey Area .....</b>	<b>2</b>
<b>3.4</b>	<b>Sampling Frame .....</b>	<b>4</b>
<b>3.5</b>	<b>Fishing Activities .....</b>	<b>4</b>
<b>3.6</b>	<b>Species .....</b>	<b>4</b>
<b>3.7</b>	<b>Survey Data Elements.....</b>	<b>4</b>
<b>4.0</b>	<b>HARDWARE .....</b>	<b>5</b>
<b>4.1</b>	<b>Hardware specifications .....</b>	<b>5</b>
4.1.1	Camera .....	5
4.1.2	Computer.....	5
4.1.3	Power supply.....	6
4.1.4	Modem .....	6
4.1.5	Antennae .....	6
4.1.6	Other .....	6
<b>4.2</b>	<b>Location specific setups .....</b>	<b>6</b>
4.2.1	Broome.....	6
4.2.2	Dampier.....	6
4.2.3	Exmouth Marina .....	7
4.2.4	Denham .....	7
4.2.5	Monkey Mia.....	8
4.2.6	Two Rocks Marina.....	8
4.2.7	Mindarie Marina .....	8
4.2.8	Ocean Reef Marina .....	8
4.2.9	Hillarys Boat Harbour (Boat Ramp) .....	9
4.2.10	Hillarys Boat Harbour (Groyne) .....	9
4.2.11	Leeuwin.....	9
4.2.12	Woodman Point (Boat Ramp).....	9
4.2.13	Woodman Point (Groyne).....	10
4.2.14	Point Peron.....	10
4.2.15	Albany.....	10
4.2.16	Esperance .....	10

<b>5.0</b>	<b>SOFTWARE .....</b>	<b>11</b>
<b>6.0</b>	<b>DATA STORAGE .....</b>	<b>11</b>
<b>7.0</b>	<b>DATA EXTRACTION.....</b>	<b>11</b>
<b>8.0</b>	<b>SECURITY AND DATA ACCESSIBILITY .....</b>	<b>12</b>
<b>9.0</b>	<b>CONCLUSIONS.....</b>	<b>13</b>
<b>10.0</b>	<b>ACKNOWLEDGEMENTS.....</b>	<b>13</b>
<b>11.0</b>	<b>REFERENCES .....</b>	<b>13</b>
<b>12.0</b>	<b>LIST OF ATTACHMENTS.....</b>	<b>15</b>

---

## 1.0 EXECUTIVE SUMMARY

Several different types of surveys (*i.e.*, access point, roving creel and phone/diary surveys) have been implemented in Western Australia to obtain data on boat- and shore-based recreational fishing since the 1990s. Recently, remotely operated cameras installed at boat ramps and groynes have provided additional data on boat- and shore-based recreational fishing to supplement knowledge obtained from other survey types. Since 2006, cameras have been installed at 14 metropolitan and regional locations throughout Western Australia to obtain such data. This report is intended to provide an understanding of how this technology has been utilised by the Department of Fisheries in Western Australia by summarising aspects of hardware, setup, software, and data extraction. Data obtained from these cameras have provided a cost-effective method of sampling boat- and shore-based fishing activity, especially at night.

---

## 2.0 INTRODUCTION

Surveys of boat- and shore-based recreational fishing are often required in Western Australia. These surveys can be conducted at large, bioregional scales (*i.e.*, West Coast bioregion) or at more localised, subregion scales (*i.e.*, Peel-Harvey estuary, Ningaloo Marine Park) depending on the information required and the management objectives. Surveys can be designed to provide annual, seasonal or monthly estimates of fishing effort, catch rate and total catch as well as to provide an understanding of fishing activity and behaviour.

Remotely operated cameras at boat ramps or groynes can be used to provide information on boat- or shore-based recreational fishing activity, respectively. Although cameras only provide information within a field of view at a specific location, they are able to provide data across an entire 24-hr day (*i.e.*, a census of activity). This method therefore provides a cost-effective method of sampling fishing activity at night, which is not often obtained due to safety considerations and high staff costs.

This report is intended to provide an understanding of how remotely operated cameras have been utilised by the Department of Fisheries in Western Australia since 2006. This includes;

- describing the scope (and limitations) of remotely operated cameras in collecting data on recreational shore- and boat-based fishing,
- describing the setup and hardware for each site where remotely operated cameras are located,
- describing the software and network systems and,
- providing a summary of the data extraction process.

Data from remotely operated cameras located throughout Western Australia have been presented in several reports and papers relating to both shore- (Smallwood et al., 2011, 2012) and boat-based (Ryan et al., 2013; Wise & Fletcher, 2013) fishing. These references provide information on incorporating these data in the estimation of fishing effort and total catch while also showcasing different techniques for presenting these data. Additionally, Wise and Fletcher (2013) provide comparisons of outputs and cost-effectiveness from remotely operated cameras and other techniques such as boat ramp surveys, vehicle counters and

ticketing machines. The benefits of using remotely operated cameras are highlighted as providing an accurate census of boating activity at a specified location (including at night), although it is noted that the majority of the costs associated with the use of remotely operated cameras is associated with data extraction and data entry, which will increase with the number of cameras installed (Wise & Fletcher, 2013). For a comparison of the cost-effectiveness of different techniques for collecting data on recreational shore-based fishing, see Smallwood et al. (2011).

---

## **3.0 SURVEY OBJECTIVES AND SCOPE**

### **3.1 Survey Objectives**

Remotely operated camera surveys (or camera surveys) can be used to provide data which assist with understanding variation in shore- or boat-based fishing activity across time and space. These data can then be used to;

- inform scheduling and planning for on-site surveys,
- validate other survey techniques and,
- adjust estimates of effort and total catch to include activity occurring outside of hours covered in on-site surveys.

For example, boat-based recreational fishing activity was monitored at 12 key boat ramps in 2011/12 using remotely operated cameras installed at each of these locations. The objective of this survey was to validate estimates of effort from the phone-diary survey over a 24-hour period. Information was gathered on the number of launches and retrievals by boat type at 5 minute intervals, with the proportion of boating activity that involved fishing to be derived from the boat ramp surveys [see Ryan et al. (2013)].

In addition, estimates of total catch and fishing effort for shore-based fishers were generated by integrating data from camera surveys with a traditional aerial-roving design. Cameras determined the distribution of shore-based fishing activity across a 24-hour day on different day types (weekend/public holiday, weekdays), while aerial surveys provided instantaneous counts for each day type as well as time of day (morning, afternoon). This information was combined with data on fishing trip length (obtained from interviews conducted during the roving creel surveys) to estimate fishing effort [see Smallwood et al. (2012)].

### **3.2 Survey Duration**

One of the key benefits of camera surveys is that they can be undertaken across a 24-hr day, and provide information on fishing activity at night. Data can also be collected over long periods of time (*i.e.*, the camera located at Ocean Reef Marina has been operational since 2006) as, once a camera is operational, sufficient data storage capability and equipment maintenance only is required to obtain a permanent record of activity. Analysis of footage is more time consuming, but can be completed at a later date.

### **3.3 Survey Area**

Camera surveys are undertaken at a specific location, within a defined field of view. Depending on the survey, observations of people or vessels can be recorded as they pass a set 'choke' point or as they enter or depart the field of view (Smallwood et al., 2011; Wise & Fletcher, 2013).

In 2006, the first remotely operated cameras were installed at four boat ramps in the Perth Metropolitan area (Wise & Fletcher, 2013) (Figure 1). In 2011/12, this was expanded to 13 cameras at key boat ramps in both metropolitan and regional locations (Ryan et al., 2013). An additional camera was installed at a boat ramp in Exmouth Marina in 2013.

In 2010, a survey of shore-based recreational fishing included data collected from cameras installed at 4 groynes in the Perth Metropolitan area (Smallwood et al., 2012) (Figure 1).

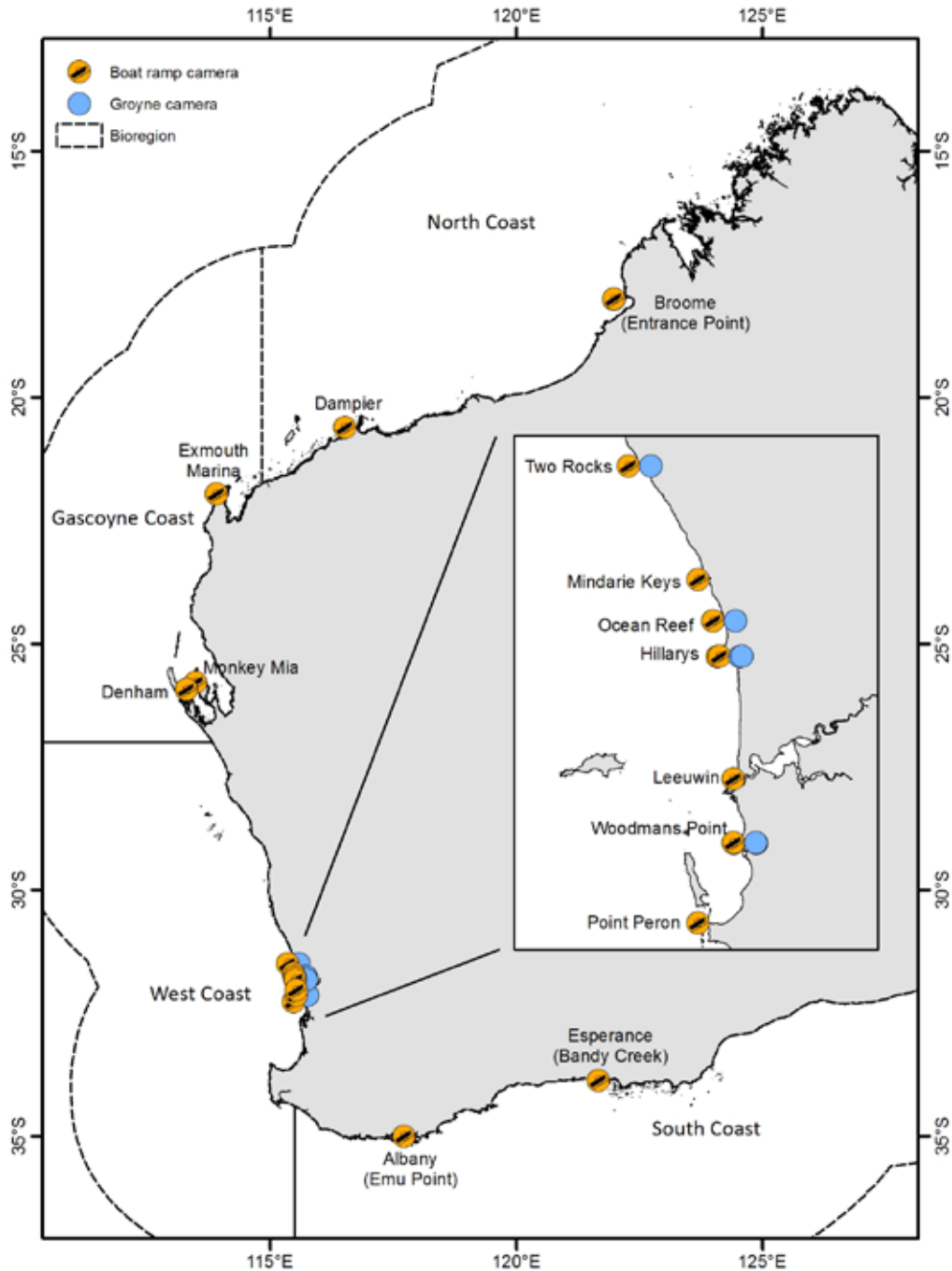

**Figure 1: Location of boat ramps and groynes monitored using remotely operated cameras.**



### **3.4 Sampling Frame**

A sampling frame is the complete set or list of all the sampling units in the population to be sampled, where the sampling unit is the basic unit (*i.e.*, often the individual angler) (Jones & Pollock, 2013). Recreational Fishing from Boat Licences are used as the sampling frame for biennial phone-diary surveys of boat-based fishers (Ryan et al., 2013), while the lack of such a licence for shore-based fishers means that a spatio-temporal sampling frame is utilised (Smallwood et al., 2012). Similarly, a spatio-temporal sampling frame is used for camera surveys. See Table 1 in Ryan et al. (2013) for a complete overview of the output specifications between survey techniques for collecting data on recreational boat-based fishing activity, including the 2011/12 camera survey.

### **3.5 Fishing Activities**

It is very important to clearly define which fishing activities are included in the scope of the survey, as this will affect data collection (*i.e.*, if the survey is targeting recreational boat-based fishing from motorised vessels, then kayaks do not need to be counted). Similarly, catch and effort statistics from charter or commercial fishing operations is generally not required, as they provide information on their fishing activities to the Department of Fisheries Western Australia on their compulsory logbook returns. Depending on the survey, fishing from jet skis may be included or excluded. Although for the majority of data collected during camera surveys in Western Australia, only data on motorised vessels is included in analysis, information on other vessel types (*i.e.*, kayaks, commercial vessels) is routinely stored when the footage is processed, and can be retrieved at a later date if necessary.

It is important to note that the activities undertaken by vessels while at sea cannot be ascertained from cameras located at a boat ramp. Information can only be determined for each individual vessel relating to its particular type, and the time when it was launched or retrieved. Information on the proportion of boats fishing is obtained from concurrent on-site interviews at these same boat ramps. It was, however, possible to assign an activity type to shore-based fishers using the remotely operated cameras based on the presence/absence of fishing gear.

### **3.6 Species**

No information on species caught by recreational boat- or shore-based fishers can be obtained from camera surveys. This is due to not only the obscured nature of catches (*i.e.*, fish are generally stored in eskies or buckets) but that the cameras are most often focussed to capture arrival or departure information, rather than the fishing activity itself.

### **3.7 Survey Data Elements**

When running concurrent surveys that need to provide comparable results, it is important to consider the unit of measurement for the various survey data elements. These may need to be standardised to be comparable or, depending on the application of each element, it may just be sufficient to clearly highlight the differences in terminology or units of measurement. Camera surveys are useful for providing data on the types of boats utilising a particular ramp, and also for highlighting the diurnal variation of boating activity across a 24-hr day in terms of launches and retrievals (Ryan et al., 2013). See Table 2 in Ryan et al. (2013) for a complete comparison of survey elements between survey techniques for collecting data on recreational boat-based fishing activity, including the 2011/12 camera survey.

---

## 4.0 HARDWARE

This section provides an overview of factors which should be considered when selecting each component of the hardware, including cameras, computers and modems. Where specific hardware products are mentioned these were selected as the most cost-effective from a limited number of products that were examined prior to the commencement of the project in 2006. The selection of specific products should not be seen as inclusive and other alternatives should be examined for technological advancements which may have been developed since this time. Otherwise, if a general reference to a component (*i.e.*, LCD monitor) is used there were a range of alternative products used to perform these tasks.

Details of the hardware installed at each location (Figure 1), including a description of the data storage capabilities and power sources utilised, are also provided. Modifications made due to operational requirements, reasons why outages may have occurred (and how such issues may have been addressed) and the date at which hardware was installed are also discussed. Advances in technology have occurred since cameras were first installed in 2006, and upgrades to equipment are also covered, where applicable.

The field of view from each camera and a schematic description of the hardware setup are provided in Attachment 1 to Attachment 16.

### 4.1 Hardware specifications

#### 4.1.1 Camera

Several criteria were utilised when selecting appropriate cameras for this research. These included;

- physical components such as durability (*i.e.*, waterproof, solid state, size)
- functionality (*i.e.*, zoom, pan and tilt capabilities)
- outputs (*i.e.*, image resolution)
- system capabilities and versatility (*i.e.*, operating system, network capable, remote access, availability of updates) and,
- cost.

Multiple products were tested as part of this process and cameras meeting these criteria were selected for this project.

#### 4.1.2 Computer

Criteria used to select an appropriate computer system included;

- small physical size (*i.e.*, some needed to fit inside very small spaces)
- operating system ( *i.e.*, not susceptible to sudden lockups and freezes and an ability to auto start)
- reliability ( *i.e.*, able to withstand extreme temperature and humidity, Hard drive performance )
- camera software compatibility (*i.e.*, time lapse function, multiple camera capability, web server, FTP function and quicktime compatible) and,
- cost

Computers meeting these criteria (in particular their small size and ability to run software used to record and transmit time lapse files at a relatively cheap cost) were selected for this project.

### **4.1.3 Power supply**

Where possible, existing main supply power connections were utilised for all equipment. However, in locations where the power supply was problematic an external Uninterruptable Power Supply (UPS) device was used to keep the camera and computer systems operational. If the power outage was for an extended period, the UPS devices were able to detect when insufficient battery power remained to run the equipment and powered them down in a safe manner. There were a number of UPS products available to perform this service.

### **4.1.4 Modem**

A number of ADSL (fixed line), 3G and 4G wireless modems were available which could provide connectivity to transfer data between locations. As large amounts of data were being transferred, consideration was given to selecting an Internet Service Provider (ISP) that could provide large download/upload limits at the best price.

### **4.1.5 Antennae**

Antennae were installed at locations where it was necessary to place the camera away from the building where the remaining equipment components (*i.e.*, computer) were located. These antennae were able to provide a “bridge” between these locations to transmit data. Criteria used to select antennae included; durability (*i.e.*, waterproof), security of frequency used to transmit data, Power over Ethernet (POE) connectivity and cost. Ubiquiti Nanostation antennae were selected as meeting these criteria at the commencement of this project.

### **4.1.6 Other**

Other components such as LCD monitors and external hard drives were available from a range of brands and were generally selected based on a value for money approach.

## **4.2 Location specific setups**

### **4.2.1 Broome**

Date installed: 14 December 2010

Setup: A Mobotix M12Msec Day/Night camera was installed at the Broome Fishing Club building situated on Kabbari Road at Entrance Point, Broome. The camera was mounted on a cross beam on the club’s service shed and cabled back to the main clubhouse office via Wi-Fi. A MacMini computer was installed in the office along with a USB backup drive, LCD monitor, ADSL modem and UPS power device. Internet Services were installed in the office on the Broome Fishing Club facsimile line while a wireless network is also running in the office to allow for remote connection outside office hours.

Issues: As Broome is in a cyclone prone area a number of options were explored to provide continuous data. Currently a pair of Ubiquiti Nanostation M5 wireless Outdoor Airmax 16 dBi antennas are placed on the service shed and main building. This allows a private wireless bridge to transmit data between both locations in the 5 GHz spectrum at 150 Mbps + speeds. Power is delivered over Ethernet (POE) to both devices, negating the installation of power points at either end. A lightning strike required the replacement of the computer, UPS power supply and LCD monitor.

### **4.2.2 Dampier**

Date installed: 17 December 2010

Setup: A Mobotix M12Msec Day/Night camera and Ubiquiti Nanostation M5 wireless Outdoor Airmax 16dBi antenna were installed on a light pole adjacent to the Dampier public boat ramp on Ian Williams Crescent. The pole is part of the Dampier street lighting and only powered during hours of darkness. A series of dry cell batteries in parallel connected to an inverter and a battery charger were used to power the camera and associated equipment during daylight hours. Access is obtained by opening the metal access housing on the pole (size 8 hex bit required). POE power injectors for the camera and wireless antenna are installed in the same area. A matching Ubiquiti Nanostation M5 wireless Outdoor Airmax 16dBi antenna is mounted on a 50 mm galvanized iron pole that is mounted to the north wall of the Dampier Yacht Club (approximately 1.5 km away). A MacMini computer is installed in the office along with a USB backup drive, ADSL modem, LCD monitor and UPS power device. Internet services are installed on the club facsimile line. A wireless network is also running in the office to allow for remote connection outside office hours.

A second Mobotix M12M camera was mounted on the Western end of the clubhouse building on the second floor. This camera overlooks the private boat ramp and yacht club facilities.

Issues: The camera at the public ramp has had some problems with power injectors and inverters. On every occasion that there was failure, it has been associated with cyclones and tropical low systems that flooded the area, causing electrical shorting of the gear. Lightning struck the pole on several occasions but has caused no damage to the camera or wireless antenna.

#### **4.2.3 Exmouth Marina**

Date installed: 28 February 2013

Setup: A Mobotix M24M sec camera was mounted on the guardrail on the upper story of the Exmouth Sea Search and Rescue Building at the Exmouth Marina. An Apple iMac computer was installed in the operations room into which the camera is directly wired. The system utilizes the Sea Search and Rescue UPS. This is a standalone system and is connected to the internet but only for incoming traffic. No data are pushed as the connection is not supplied by the Department of Fisheries Western Australia and this site is visited regularly to download the data.

Issues: The iMac computer was replaced at this location in January 2014 with an Apple MacMini.

#### **4.2.4 Denham**

Date installed: 15 July 2009

Setup: A Mobotix M12Msec Day/Night camera and Ubiquiti Nanostation M5 wireless Outdoor Airmax 16dBi antenna are installed on a light pole adjacent to the Denham public ramp on Knight Terrace. Power is supplied directly to the pole and a small metre box is installed on the pole which contains the power injectors for the camera and Nanostation. A matching Ubiquiti Nanostation M5 wireless Outdoor Airmax 16dBi antenna was mounted on a 50 mm galvanized iron pole to the south wall of the Shark Bay Sea Rescue Building (approximately 600 m away).

A MacMini computer was installed in the Shark Bay Sea Rescue office along with a USB backup drive, ADSL modem, LCD monitor and UPS power device. Internet services are installed on the club facsimile line. A wireless network is also running in the office to allow for remote connection outside office hours.

Issues: One camera has been replaced, along with two power injectors, due to a lightning strike and flooding associated with a cyclone.

#### **4.2.5 Monkey Mia**

Date installed: 26 June 2009

Setup: A Mobotix M22Msec camera was mounted on the eastern wall of the “Fish Room” on the Department of Parks and Wildlife building at Monkey Mia. A MacMini computer, wireless 3G modem, LCD monitor and backup drive were also installed at this location. A wireless network was also running in the office to allow for remote connection outside office hours. There is no Asymmetric Digital Subscriber Line (ADSL) available at Monkey Mia. Due to the cost of data transfer via 3G in this location, data are downloaded by research staff.

Issues: There was one outage (4 weeks) with this gear which was the result of the accidental cutting of the power supply cabling, shorting out the camera injector and router.

#### **4.2.6 Two Rocks Marina**

Date installed: 4 February 2009

Setup: A Mobotix M22M camera was mounted on the upper story walkway of the Two Rocks Sea Rescue building. A MacMini computer, ADSL modem and backup drive were installed in the radio room of the same building. A wireless network was also running in the office to allow for remote connection. Data were pushed to the servers at Hillarys Fisheries and Marine Research Laboratories every hour during the survey periods.

Issues: The internet connection was taken over by the Sea Search and Rescue group and as such Department of Fisheries Western Australia no longer pushes live vision to its servers. The site is visited every 5–6 months and the data copied manually.

#### **4.2.7 Mindarie Marina**

Date installed: 18 November 2010

Setup: A Mobotix M22Msec camera was mounted under the eaves on the north western part of the roof on the Mindarie Marina Management building off Ocean Falls Boulevard. A MacMini computer and backup drive were installed in the security office of the same building. This is a standalone system that does not have an internet connection. This site is therefore visited each month to download the data.

Issues: To date, only one short-term loss of data has occurred due to a power failure and the computer not automatically restarting (initial setup oversight). However, two outages of data collection occurred in 2012 and 2013 due to flooding and damage to computers.

#### **4.2.8 Ocean Reef Marina**

Date installed: 10 March 2006

Setup: A Mobotix M10Msec Day camera was installed under the eaves on the western side of the Whitfords Sea Rescue Building on the third floor at the Boat Harbour on Quay Road. A MacMini computer, a wireless 4G modem and backup drive were installed in the security office of the same building. A wireless network is also running in the office to allow for remote connection outside office hours.

Issues: There has been some data loss at this site due to the MacMini accidentally being switched off on several occasions.

#### **4.2.9 Hillarys Boat Harbour (Boat Ramp)**

Date installed: 8 August 2005

Setup: An Axis 213 PTZ was initially installed at this location but this camera failed and was replaced with a Mobotix M24M sec camera capable of providing images at a higher resolution. These cameras were mounted at the same location under the eaves on the southern side of the second floor at the Hillarys Fisheries and Marine Research Laboratories. Data from this camera are captured directly into the central server in the server room in this building.

Issues: There has been one loss of data (three weeks) due to a core network switch being replaced. This switch connected the camera to the server for data storage and capture.

#### **4.2.10 Hillarys Boat Harbour (Groyne)**

Date installed: 27 March 2010

Setup: Two Mobotix Q24M cameras (1 day, 1 night) were installed on a light pole placed on the roof of the pump house at the Hillarys north wall to record a 180 degree view along the groyne. The cameras were attached to a MacMini computer and backup drive housed in the pump house.

Issues: These cameras were not connected to the network as no fibre channel link was available prior to the start of the shore-based recreational fishing survey and data was therefore retrieved manually.

#### **4.2.11 Leeuwin**

Date installed: 17 February 2011

Setup: A Mobotix M24M sec camera is mounted on a pole overlooking the Leeuwin Public boat ramp next to the Swan River at Riverside Road, East Fremantle. A MacMini computer, backup drive, wireless 4G modem and power injector for the camera are contained within a metal meter box installed on the same pole. Power is supplied directly to the meter box.

Issues: The boat ramp was refurbished during November 2012 – May 2013 and the unit was repositioned onto a new light tower slightly north of its original position. No data were recorded during this period due to power outage during the construction phase.

#### **4.2.12 Woodman Point (Boat Ramp)**

Date installed: 6 December 2005

Setup: A Mobotix M24M sec camera was mounted under the eaves on the third floor of the Cockburn Power Boat Club building at Jervoise Bay Cove. A second Mobotix M12M sec day/night camera was mounted alongside on the southern side. A MacMini computer, wireless 4G modem and backup drive were installed in the radio room. A wireless network is also running in the office to allow for remote connection outside office hours.

In January 2013, all the equipment was relocated to the Cockburn Sea Rescue facility in the same compound. Cameras have been placed on a galvanized pole mounted on the southern roof apex of the building. The computers, switches, modems and monitors have been relocated to the radio room on the upper floor of the building.

Issues: Data loss occurred on several occasions due to power outages requiring manual restarts of the camera. When these outages occurred on a Friday the equipment was rebooted on the following Monday.

#### **4.2.13 Woodman Point (Groyne)**

Date installed: 30 March 2010

Setup: An Axis 213 PTZ camera was mounted on the rooftop of the Cockburn Power Boat Club. This camera was replaced in 2008 with Mobotix cameras. These newer cameras were connected into the boat ramp system at the Cockburn Power Boat Club and were used for the shore-based recreational fishing survey from April – June 2010.

#### **4.2.14 Point Peron**

Date installed: 10 April 2006

Setup: An Axis 213PTZ camera was initially mounted on the western wall of the security gate on the causeway leading to the Garden Island Navy base. This camera was installed in April 2006, but was later replaced with a Mobotix M24M sec camera. A MacMini computer, LCD monitor, wireless 4G router and backup drive were installed in the security room. A wireless network is also running in the room.

Initially a wireless network bridge was established using Ultra Wap wireless routers that transmitted to the Rockingham Sea Rescue Building approximately 400 m away. A wireless modem/router and internet connection was established on the facsimile line. Data were transmitted across this link. The Ultra Wap wireless routers were replaced with a wireless 4G modem/router.

Issues: In mid-September 2011 the Axis camera failed and shorted out the MacMini ethernet port and the power supply. The camera was replaced with a Mobotix M24M sec camera and a new MacMini was installed.

#### **4.2.15 Albany**

Date installed: 20 December 2010

Setup: A Mobotix M12M sec camera is mounted on the eastern Wall of the Albany Sea Rescue building at Emu Point public boat ramp at Swarbrick Street. A MacMini computer, LCD monitor, wireless modem/router and backup drive were installed in the office of the building. A wireless network is also running in the room for out-of-hours access to the system. An ADSL internet connection was established on the facsimile line.

Issues: There has only been a small loss of data due to the gear being switched off by accident in the office. Modifications to the car park and boat ramp area between January and March 2013 resulted in infrequent power outages.

#### **4.2.16 Esperance**

Date installed: 31 December 2010

Setup: A Mobotix M12M sec camera was mounted on the south western wall of the Esperance District Fisheries office shed overlooking the Bandy Creek Boat Harbour and public boat ramp. The camera has a 135 mm and 22 mm lens attached for overall harbour views and zoomed views of the public boat ramp 400 m away. A MacMini computer, LCD monitor, wireless 3G modem and backup drive were installed in the shed. A wireless network is also running in the room for out-of-hours access to the system.

This equipment was originally setup in the district office building utilizing EOP adaptors. However, it was relocated to the shed after two months due to the unreliable power distribution system at the camera site.

*Issues:* The camera was switched to 60 day rolling collection of data from March 2012 – October 2013 resulting in vastly increased storage size and loss of data. An additional large capacity hard drive was fitted in February 2014 and set to capture continuous data.

---

## **5.0 SOFTWARE**

Cameras were setup to capture data internally and push the information out to a centralised storage site when a network connection was available. They perform this function very well for live data capture, frame capture series of data and motion detection capture. However, the use of third party software was required to stitch all the images together from the format that the Mobotix cameras produce (mjpeg).

A full motion video capture of every second of the day was not feasible as the storage requirements for a year of data would have been unnecessarily large, and would have extended the reading time. Therefore, a time lapse approach for video capture was deemed more appropriate.

Using this approach one frame of video was captured every eight seconds and compiled into a .mov file, where each file comprised one hour of actual elapsed time and was stored in separate folders for each day on the computer. This file was then ‘pushed’ to the centralized server at the Hillarys Fisheries and Marine Research Laboratories and backed-up on site. Security Spy software was used to accomplish this task (Bensoftware, 2014).

---

## **6.0 DATA STORAGE**

The majority of the remotely operated cameras are connected to the internet via ADSL or 3G and 4G wireless. Where possible, the same service provider was used across locations to maximise data allowances and keep costs down. All cameras have a dynamic domain name assigned so they can be contacted if there are IP address changes.

Data are stored at Hillarys Fisheries and Marine Research Laboratories. A Network Attached Storage device stores all the analysed .mov files. Hourly data files of captured footage from most locations are pushed to this site hourly.

---

## **7.0 DATA EXTRACTION**

Each file consisted of one hour of actual elapsed time condensed into a time lapse .mov file. Each frame in the file has a time stamp which shows the camera name, date and time. As the file is a movie file it plays back at 25 fps which allows a complete hour of footage captured at one frame every eight seconds to be played back in 23 seconds. This allows a quick scan of the file to see if any vessel/people movement occurred. If there is, playback is stopped at the desired place and the information entered into a database.

The following information is captured;

- Location
- Date



- Vessel type (powerboat, canoe/kayak, commercial vessel, yacht, jet ski, other, unknown)
- Launch time
- Retrieval time
- Private or public ramp, and
- Reader

To ensure consistent identification of launch and retrieval times between readers, a reference line between two known points is used as the trigger point for data capture (refer to Attachment 9 for an example). This overcame the issue where vessels floated around for up to 15 minutes while waiting to retrieve due to overcrowding at some ramps.

In addition, it was not uncommon for a boat to be launched and then tied up alongside the ramp for a great deal of time while gear was put aboard or while the occupants waited for someone to arrive. Also, some boats were only launched to test a motor alongside the ramp and were retrieved without ever going out to sea. If the vessel passed the reference point it was considered to be a launch or retrieval. Conversely, if a boat did not pass the reference point, it was not recorded.

Another issue was that a boat launched at one ramp did not always retrieve at the same ramp. Thus, the launch and retrieve counts did not always match. Some boat ramps may also have several launches in one day with no retrievals (or vice versa) if vessels are on overnight trips. Due to these imbalances it may be necessary to ‘reset’ the count of people or vessels to zero at a known time (*i.e.*, midnight) (especially at extremely busy ramps).

Although the time lapse method was selected for implementation in surveys prior to June 2014, it is possible to capture a frame or video stream using event windows and event logic settings when certain parameters are met. Initial trials of a .txt file automatically sent to a server containing a photograph, time, camera name and event information when movement was detected at a ramp were ruled out due to the complexities around false detections generated from surface water movement. In addition, elements such as rough water, birds, boat wakes, sea spray and waves continually triggered the cameras. To address this problem cameras were reprogrammed by altering the sensitivities, which worked fine for the conditions they was set for, but failed when the conditions changed (*i.e.*, calm vs. wild weather).

New firmware installed in some of the cameras now allows for the event logic method described above due to vast improvements in the movement detection algorithms installed in the cameras. Initial trials have commenced to test the viability of this method for automatic counts of boat movements.

---

## **8.0 SECURITY AND DATA ACCESSIBILITY**

Cameras and data storage devices are kept in secure locations where possible (*i.e.*, Department of Fisheries Western Australia office or Sea Search and Rescue building) to restrict vandalism and theft of equipment. Anti-vandalism devices were also installed on some cameras which are located in more exposed or accessible positions (*i.e.*, Hillarys groyne camera).

Western Australian Police require any cameras placed in public locations to be registered in their system, and all the cameras installed by the Department of Fisheries Western Australia at boat ramps and groynes meet this criterion. Signs were also placed at every location at which a camera was installed to alert members of the public that they may be under video surveillance by the Department of Fisheries Western Australia.

No personal information such as number plates is collected by the cameras and individual fishers cannot be identified from the footage. Footage collected by cameras could be viewed (subject to privacy controls) by the organisations who hosted the equipment, and by members of the public on request, although there was no functionality to allow the deletion of any files from a data storage device. Security settings can also be changed via the Security Spy software to meet a range of circumstances, as necessary (*i.e.*, to limit or increase access as required).

---

## 9.0 CONCLUSIONS

Remotely operated cameras have been utilised throughout Western Australia since 2006 to collect data on boat- and shore-based recreational activity occurring at boat ramps and groynes. This technology has provided a cost-effective method for collecting such information from across widely distributed locations for long time periods. However, the efficient collection of video footage needs to be balanced against the length of time required for data processing, and the costs associated with providing staff to undertake this work. Ongoing developments in camera technology, as well as data storage and power, will continue to provide more options and efficiencies in the collection of recreational fishing information. In addition, software developments are also likely to continue to improve the efficiency of data extraction (*i.e.*, by automating data processing procedures) and increase the level of information able to be obtained (*e.g.*, data on boat length).

---

## 10.0 ACKNOWLEDGEMENTS

The authors would like to acknowledge the efforts of the many staff who assisted with the data processing, namely; Gary Choney, Grace Davis, Cameron Desfosses, Stacey Dorman, Kim Gray, Rhiannon Guy, Annique Harris, Karina Inostroza, Danielle Kelly, Danielle Kyrwood, Tegan Richards, Nikki Simmons, Elena Sulin, Alissa Tate and John Urbanski. We would also like to acknowledge the assistance of Steve Guy with some technical aspects of the project.

The authors would finally like to thank Dave Abdo, Karina Ryan, Stephen Taylor, Corey Wakefield and Brent Wise for reviewing this report.

---

## 11.0 REFERENCES

Bensoftware (2014). *Bensoftware*. <http://www.bensoftware.com/>. Date accessed: 12 June 2014.

Jones, C. M. and Pollock, K. H. (2013). Recreational angler survey methods: estimation of effort, harvest and released catch over a range of spatial and temporal scales. In *Fisheries Techniques (3rd Edition)*. Zale, A. V., Parrish, D. L. and Sutton, T. M. (Eds). American Fisheries Society, MD. pp. 883-919.

Ryan, K. L., Wise, B. S., Hall, H. G., Pollock, K. H., Sulin, E. H. and Gaughan, D. J. (2013). *An integrated system to survey boat-based recreational fishing in Western Australia 2011/12* (Fisheries Research Report No. 249): Department of Fisheries, Western Australia. 162 pp.

Smallwood, C. B., Pollock, K. H., Wise, B. S., Hall, N. G. and Gaughan, D. J. (2011). *Quantifying recreational fishing catch and effort: a pilot study of shore-based fishers in the Perth Metropolitan area* (Fisheries Research Report No. 216). Perth, Western Australia: Western Australian Department of Fisheries. 60 pp.

Smallwood, C. B., Pollock, K. H., Wise, B. S., Hall, N. G. and Gaughan, D. J. (2012). Expanding roving-aerial surveys to include counts of recreational shore fishers from remotely-operated cameras: benefits, limitations and cost-effectiveness. *North American Journal of Fisheries Management*. 32: 1265-1276.

Wise, B. S. and Fletcher, W. J. (2013). *Determination of cost effective techniques to monitor catch and effort in Western Australian demersal finfish fisheries* (Fisheries Research Report no. 245, FRDC Project No 2005/034 and WAMSI Subproject 4.4.3). Perth, Western Australia: Western Australian Department of Fisheries. 162 pp.

## 12.0 LIST OF ATTACHMENTS

### Attachment 1: Broome

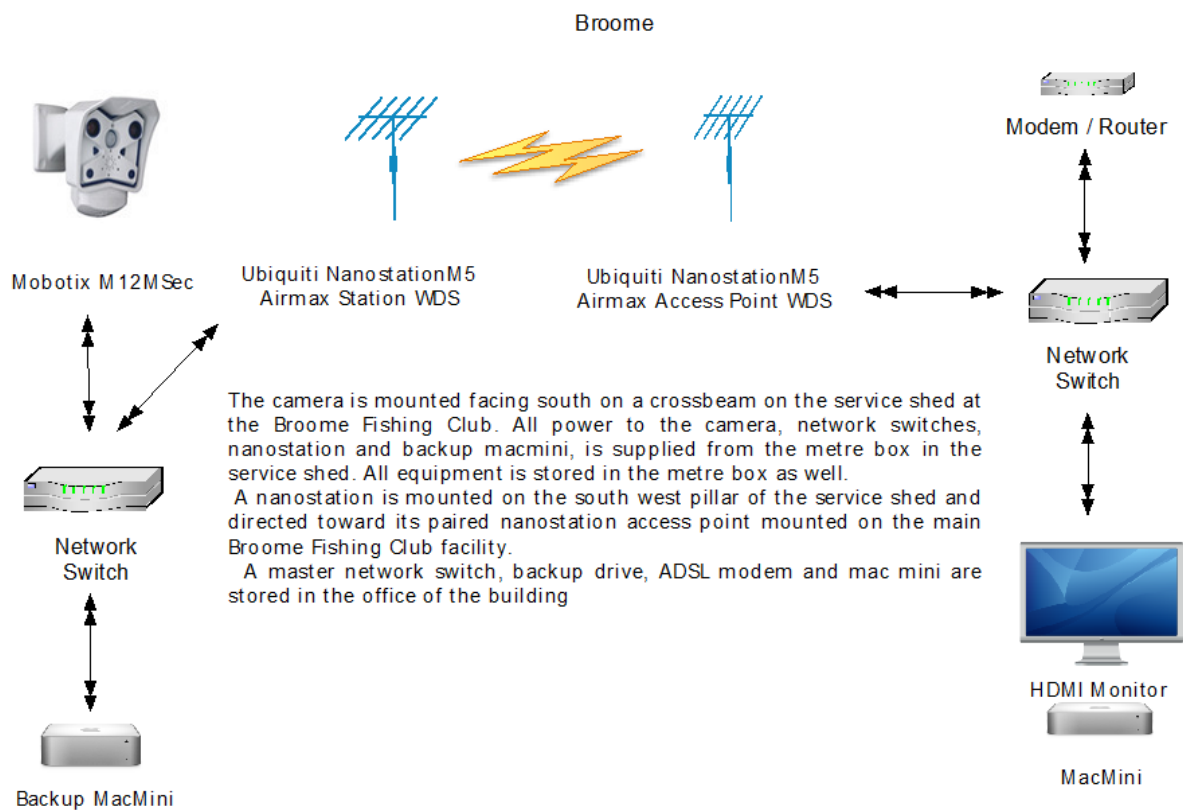

## Attachment 2: Dampier

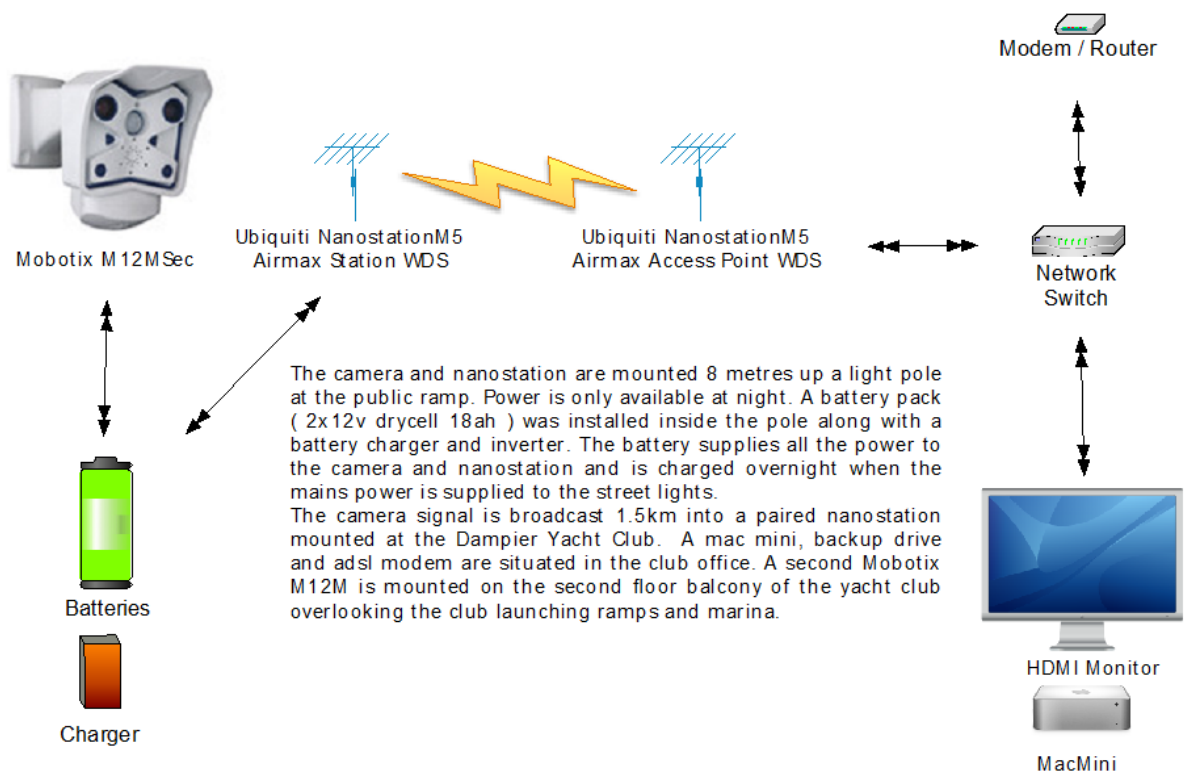
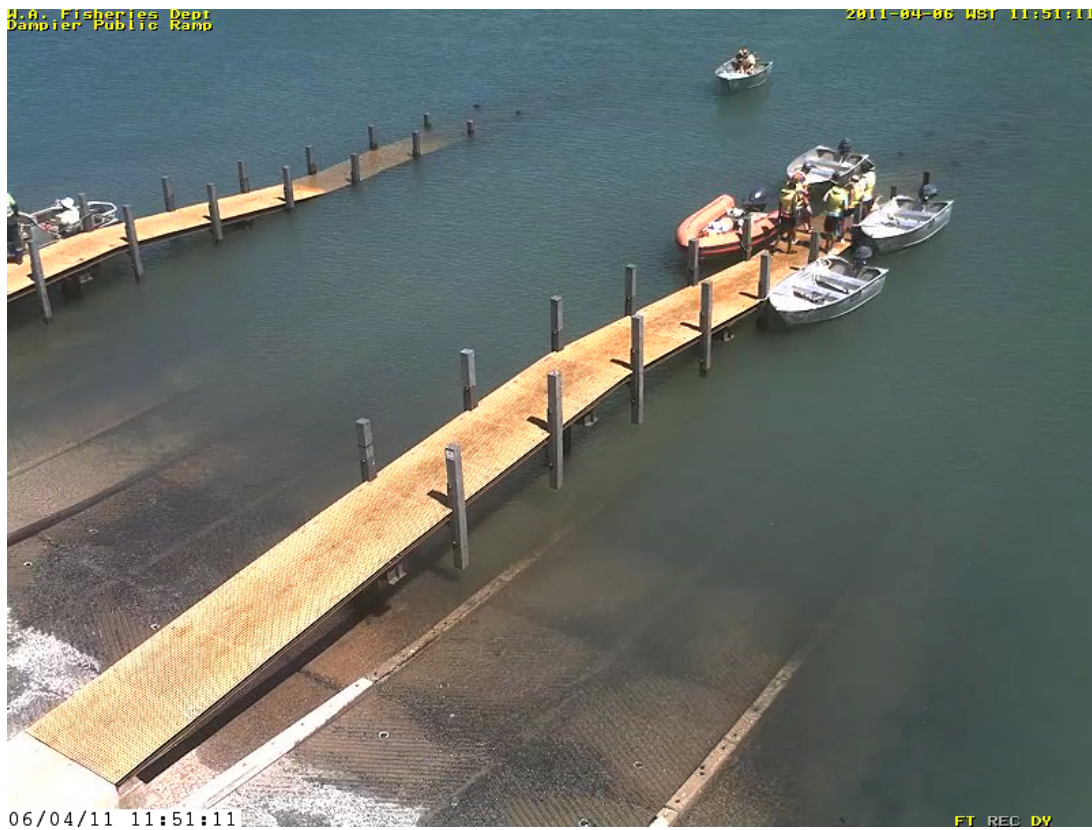

### Attachment 3: Exmouth Marina



Exmouth

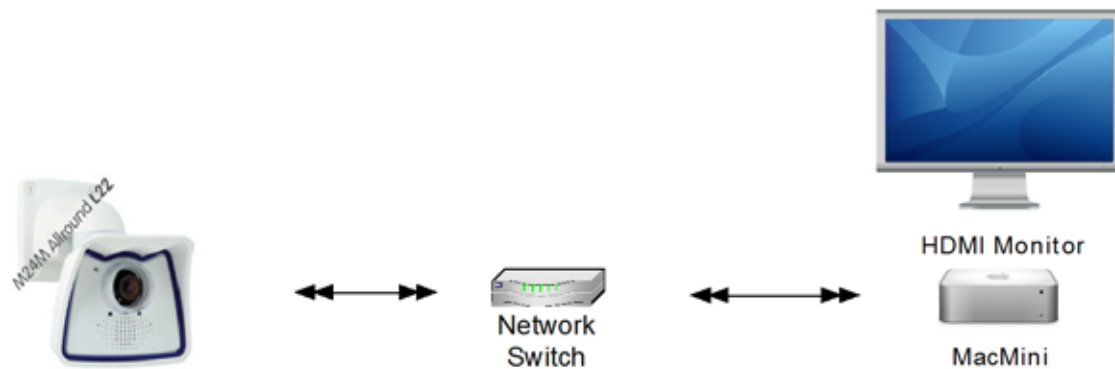

Mobotix M24MSec

The camera is bolted to the guardrail on upper deck on the eastern side of the Exmouth Sea Rescue building. A mac mini is located in the radio room below. This camera is not connected to the internet.

## Attachment 4: Denham

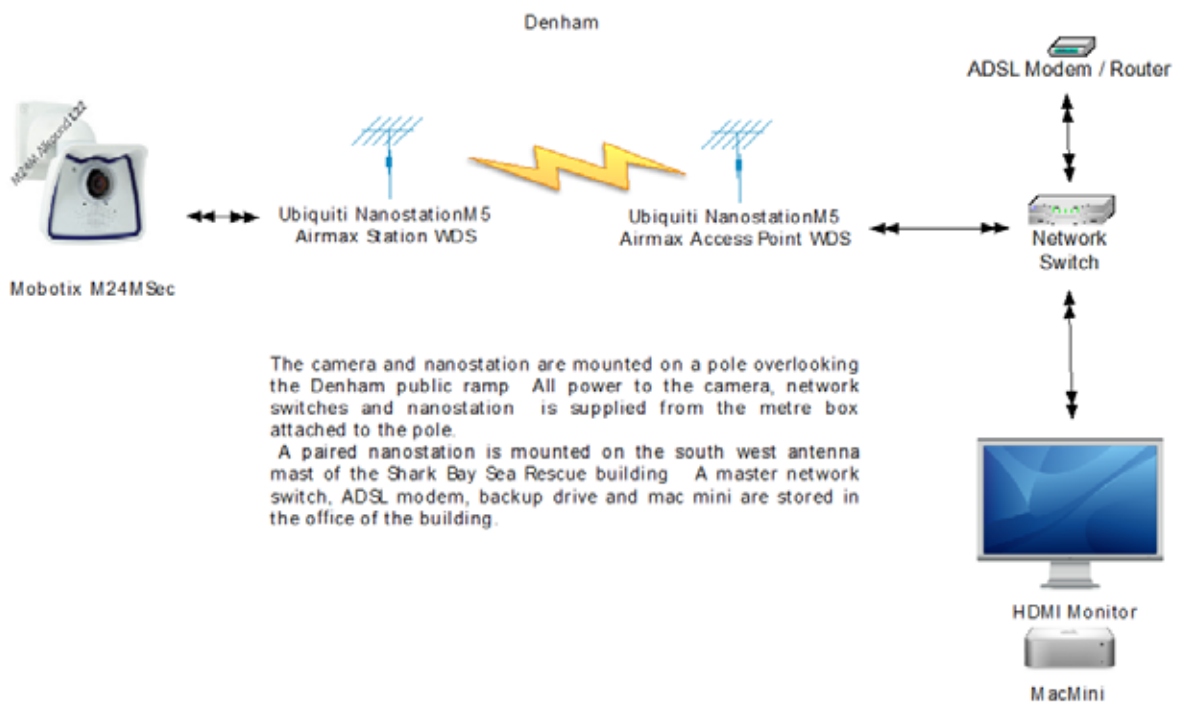

## Attachment 5: Monkey Mia

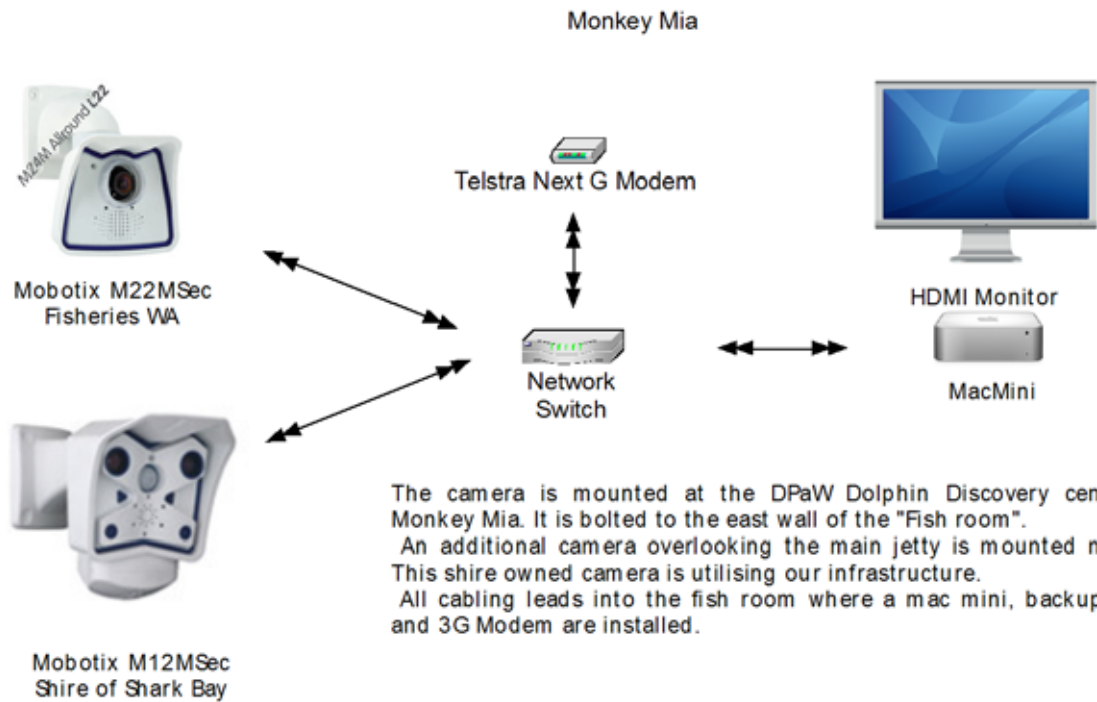



## Attachment 6: Two Rocks Marina

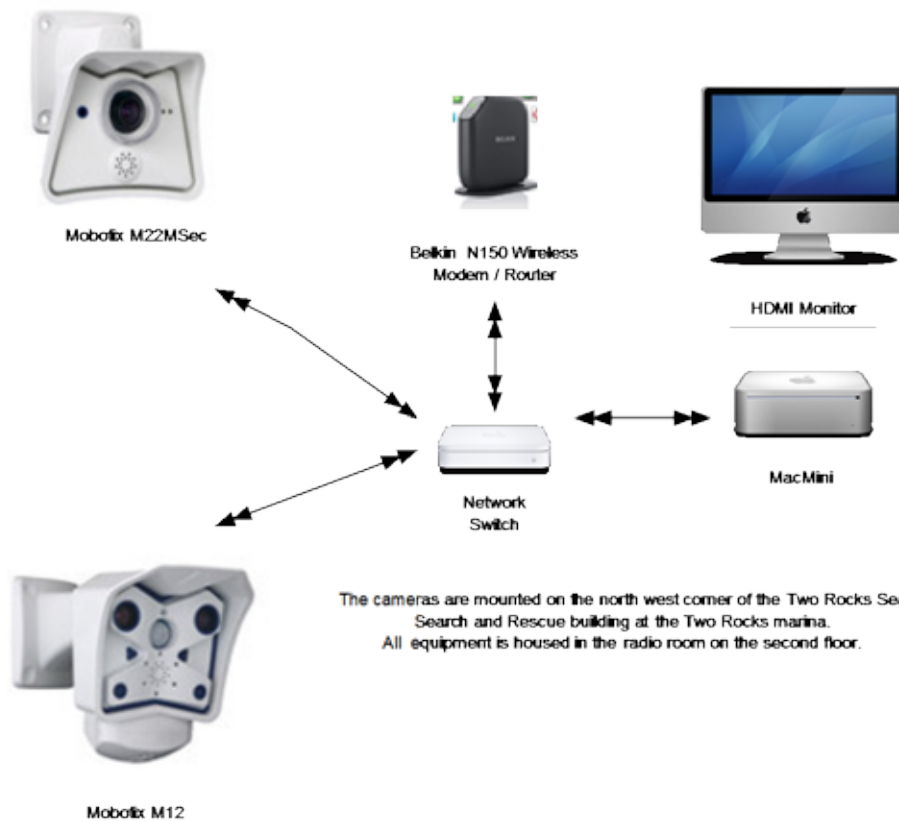

## Attachment 7: Mindarie Marina

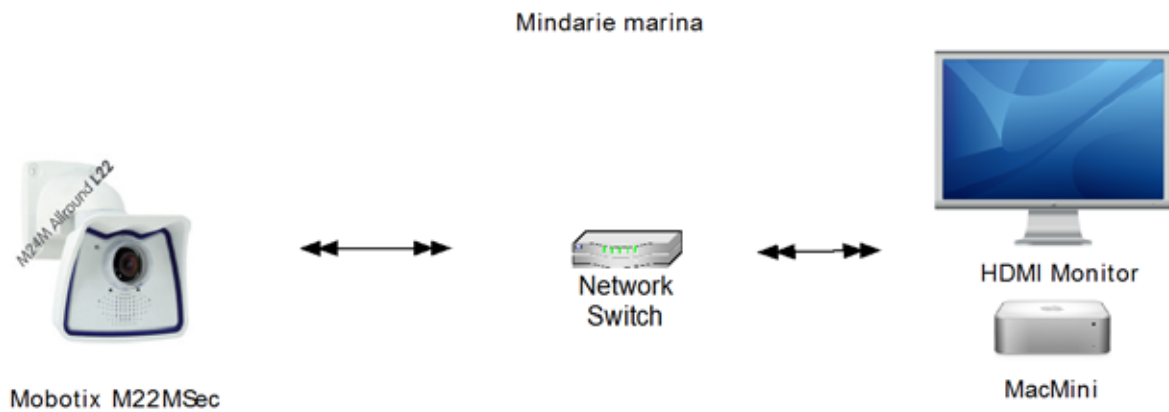
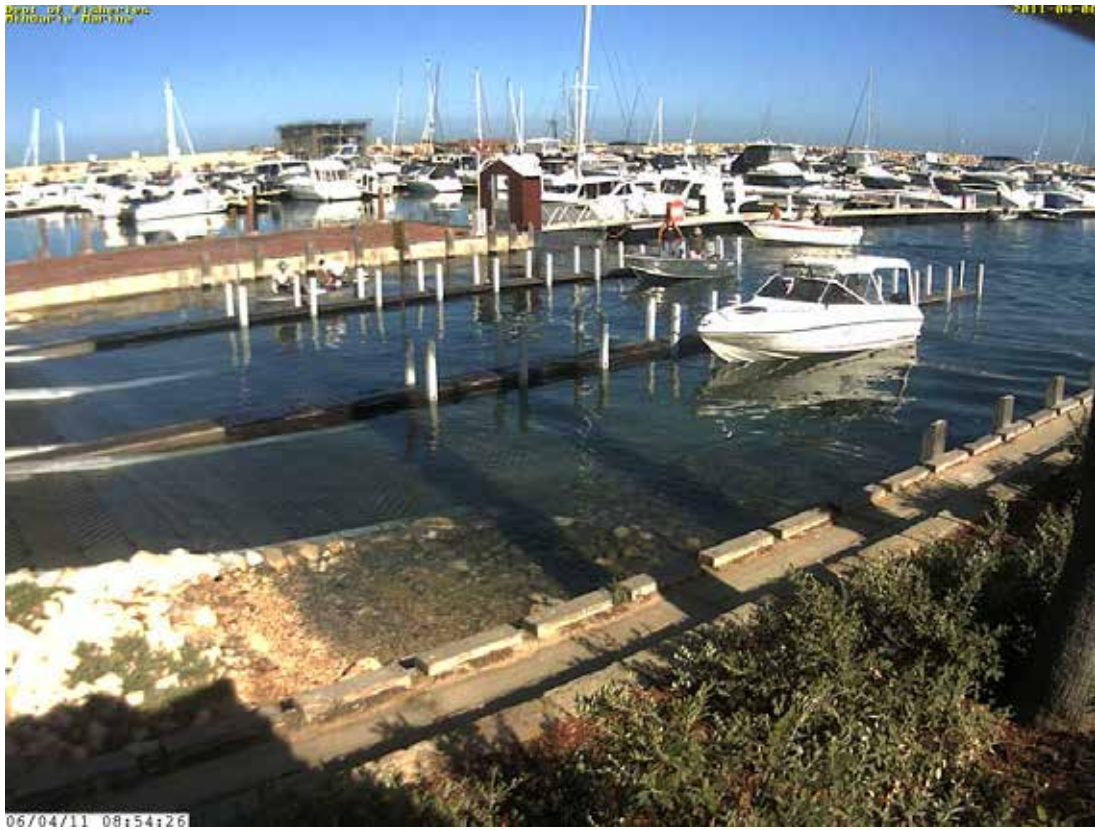

The camera is mounted on the north west corner of the Mindarie Marina services building located next to the boat ramp. A network switch and mac mini are located in the security room. There is no internet connection from this camera

## Attachment 8: Ocean Reef Marina



Ocean Reef

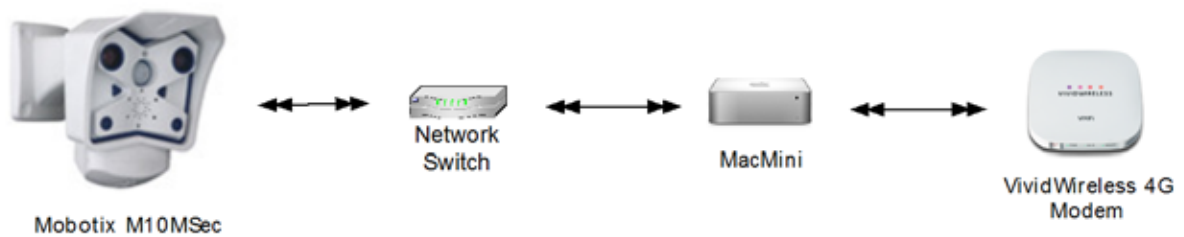

The camera is bolted to a beam on the external walkway at the Whitfords Sea Rescue Building. A mac mini, network switch and vividwireless modem are housed in the main tower building on the upper floor.

### Attachment 9: Hillarys Boat Harbour (Boat Ramp)



The yellow line drawn across 2 known points served as the trigger point for data capture.

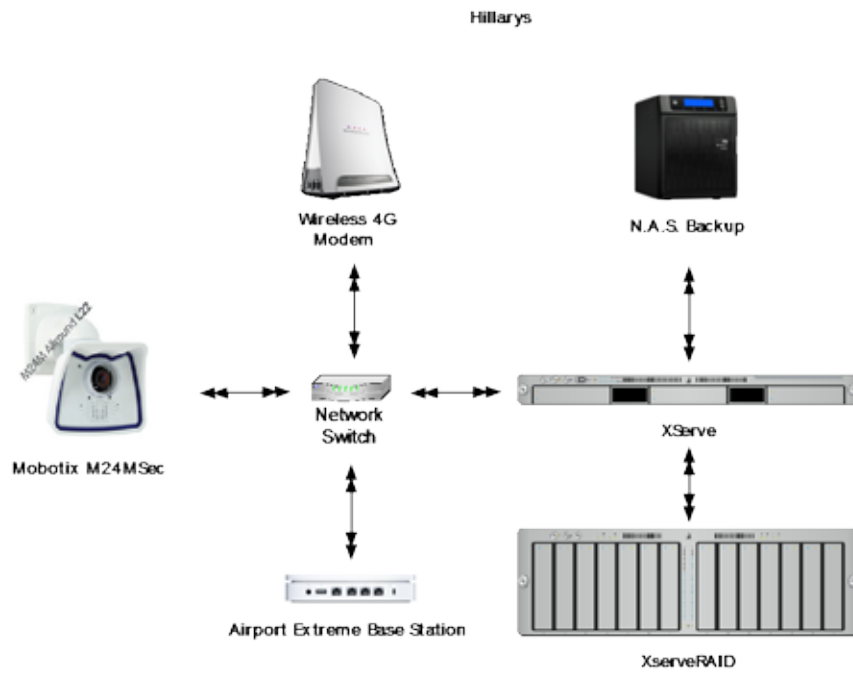

## Attachment 10: Hillarys Boat Harbour (Groyne)



Hillarys Groyne

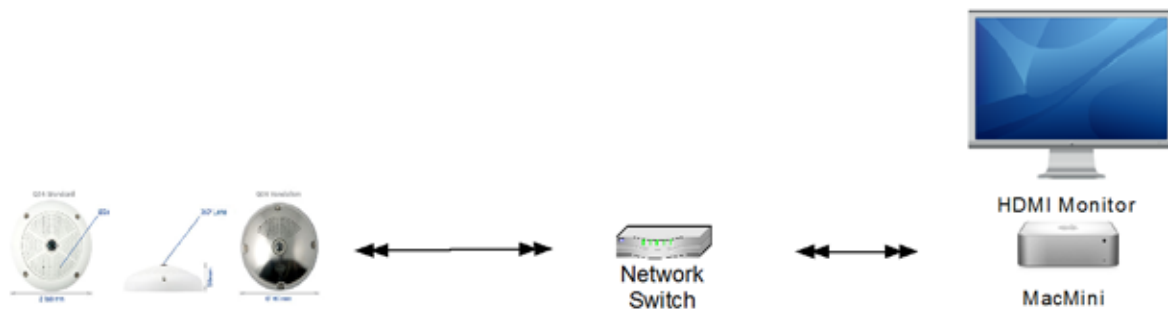

2 x Robotix Q24  
Day / Night

2 x Q24 cameras are bolted to the top of a 6m lamp post on top of the departments pump house on the north groyne at Hillarys Boat Harbour, A mac mini is located in the pump house below. These cameras are not connected to the internet.

## Attachment 11: Leeuwin



Leeuwin

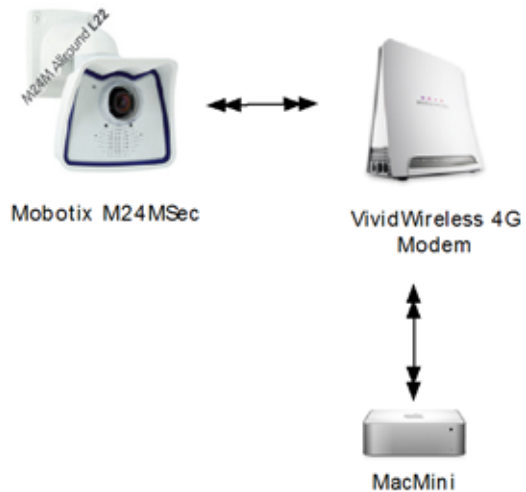

A small metal box is attached to a power pole overlooking the main ramp.

The camera is attached externally on this box. A mac mini and Vividwireless 4G modem are stored inside the box. Power is supplied directly to the box.

## Attachment 12: Woodmans Point (Boat Ramp)

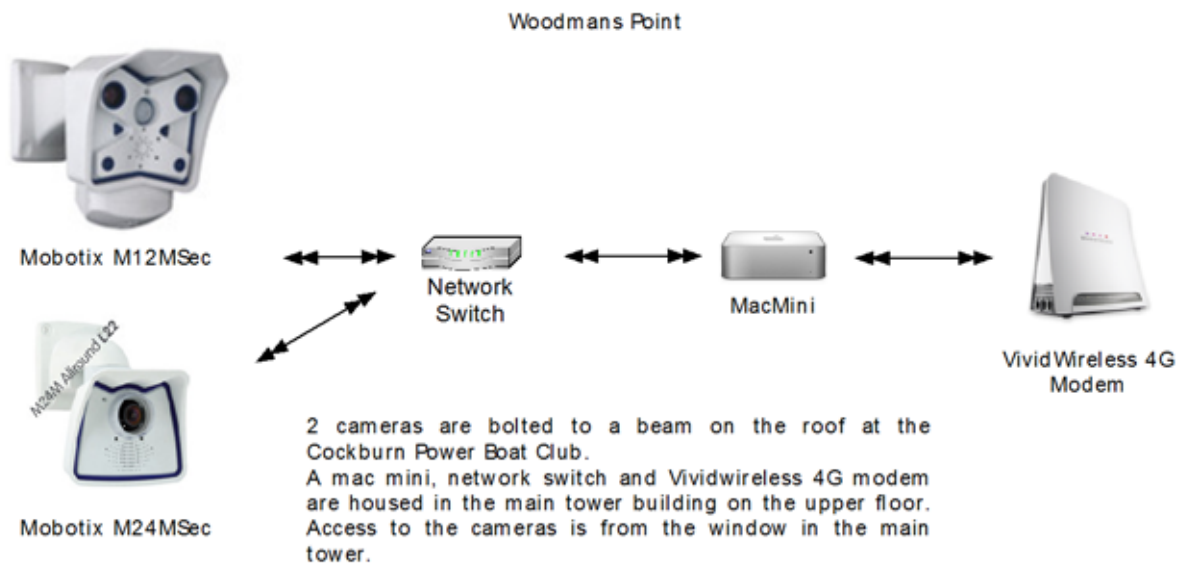

### Attachment 13: Woodman Point (Groyne)



Woodmans Point

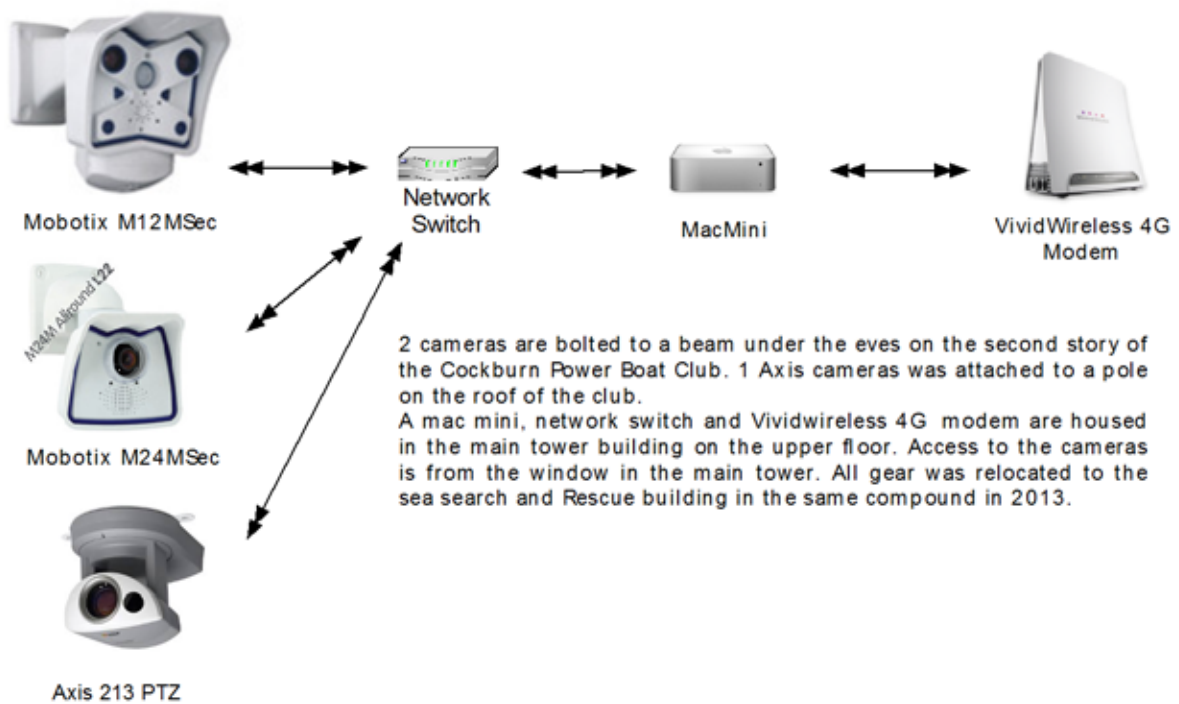



## Attachment 14: Point Peron



Point Peron

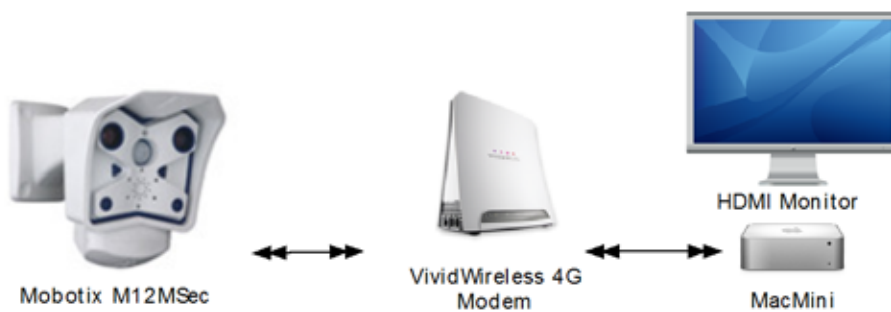

The camera is bolted to the western wall of the military checkpoint building on the Garden Island causeway. A mac mini and Vividwireless 4G modem are housed inside the checkpoint.

### Attachment 15: Albany



#### Emu Point - Albany

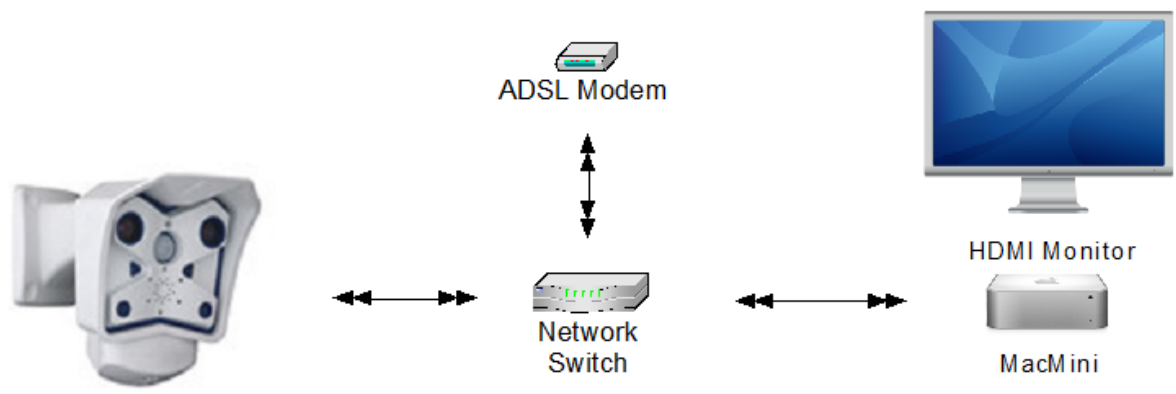

Mobotix M12M Sec

The camera is bolted to the eastern wall of the Albany Sea Rescue building. A mac mini, backup drive and adsl modem are housed in the office in the main building

## Attachment 16: Esperance



Esperance

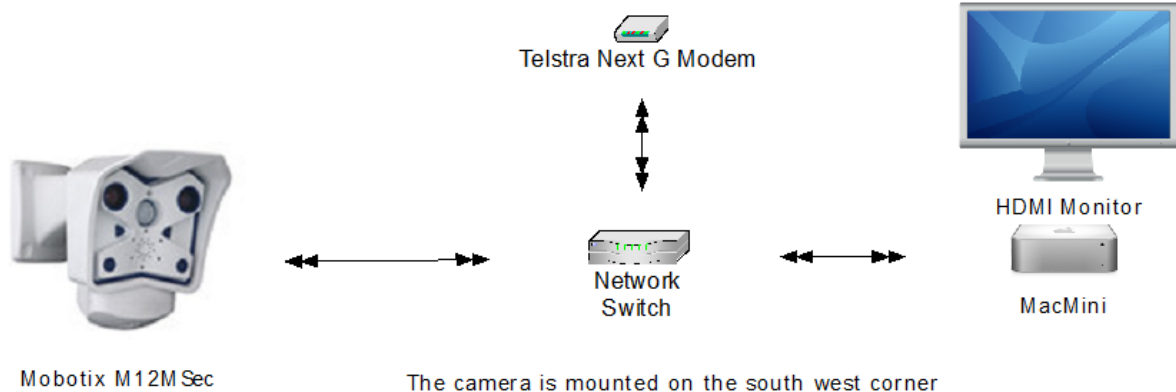

The camera is mounted on the south west corner of the boat shed at the Dept of Fisheries building at Bandy Creek. A mac mini, backup drive and 3G modem are stored inside the shed.



